

Portfolio of Tonia Gkougkouli

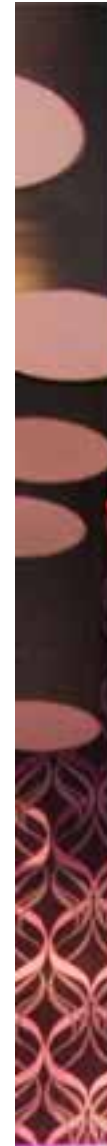

resume:

My name is Tonia Gkougkouli and I'm ARB member and RIBA chartered member. I have a degree in Architecture from N.T.U.A. (National Technical University of Athens). I have also made studies in Interior Design (pending degree) in Technological Educational Institute of Athens. Since 2005, I have practiced architecture and interior design on several projects in Greece, including residences, offices and commercial projects. The last 9 years, I was involved (co-owner) in architectural practice ArkiTopo, based in Athens, as Project and Design manager.

My main responsibilities were project design following client's needs and desires, planning application process according to Greek building regulations and supervising building construction projects. I am familiar with many of the CAD software involved in architectural designing (AutoCAD, Architectural Desktop, 3D max, V-Ray). During my career, I have attended many courses organized by the Institution of Education for the members of the Technical Chamber of Greece such as Energy audit and Issuance of Energy Certification of buildings, Construction Law & Procedure for Building Development, Natural Lighting design for energy savings. Since 2013, I am energy inspector and manager in Greece.

This portfolio contains selected reference projects during my career.

Contents

INTERIORS:

Booking.com Offices refurbishment, Athens, Greece.....	3
Booking.com Offices refurbishment, Thessaloniki, Greece.....	4
Night Club, Glyfada, Attiki, Greece.....	5
Remodeling of a Retail store (Framing, Cards, Posters), Patra, Greece.....	6
Hair-salon design Neo Hrakleio, Attiki, Greece.....	7
Café bar in Plaka, Athens, Greece	8
Interior design of a Hotel room, “Room 18”, Competition 2016.....	9

FURNITURE:

Bespoke furniture for Offices.....	10
Bespoke sofa - study.....	11
Bespoke storage console.....	12

SKETCHES:

Sketches from various projects.....	13
-------------------------------------	----

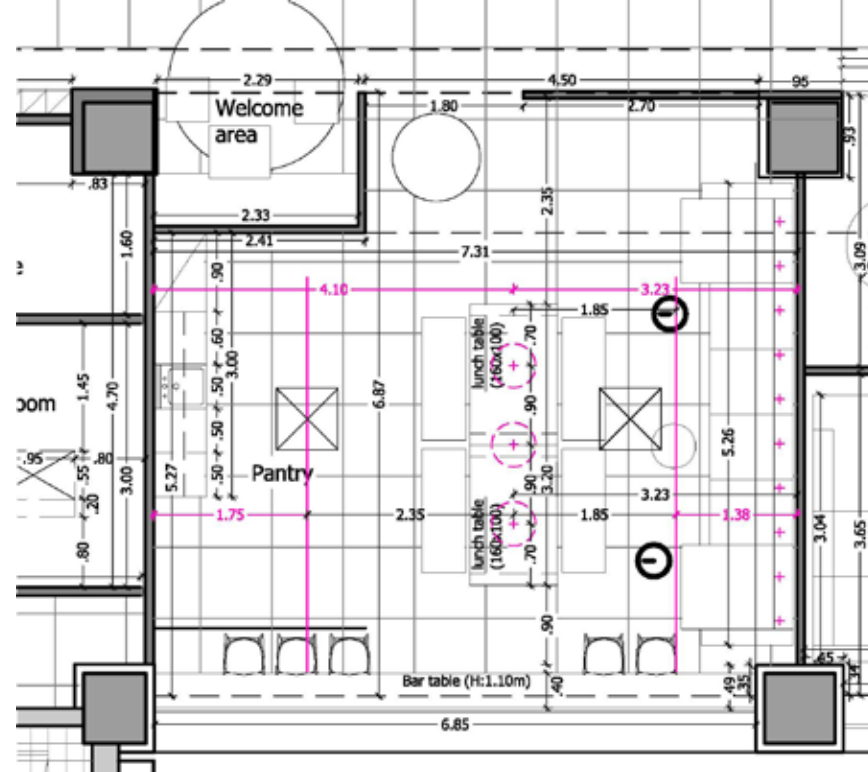

Booking.com Offices refurbishment,
Athens, Greece

Space Area: 800 sq.m.
Design Date: 03/2014-06/2014
Status: Complete, 2014

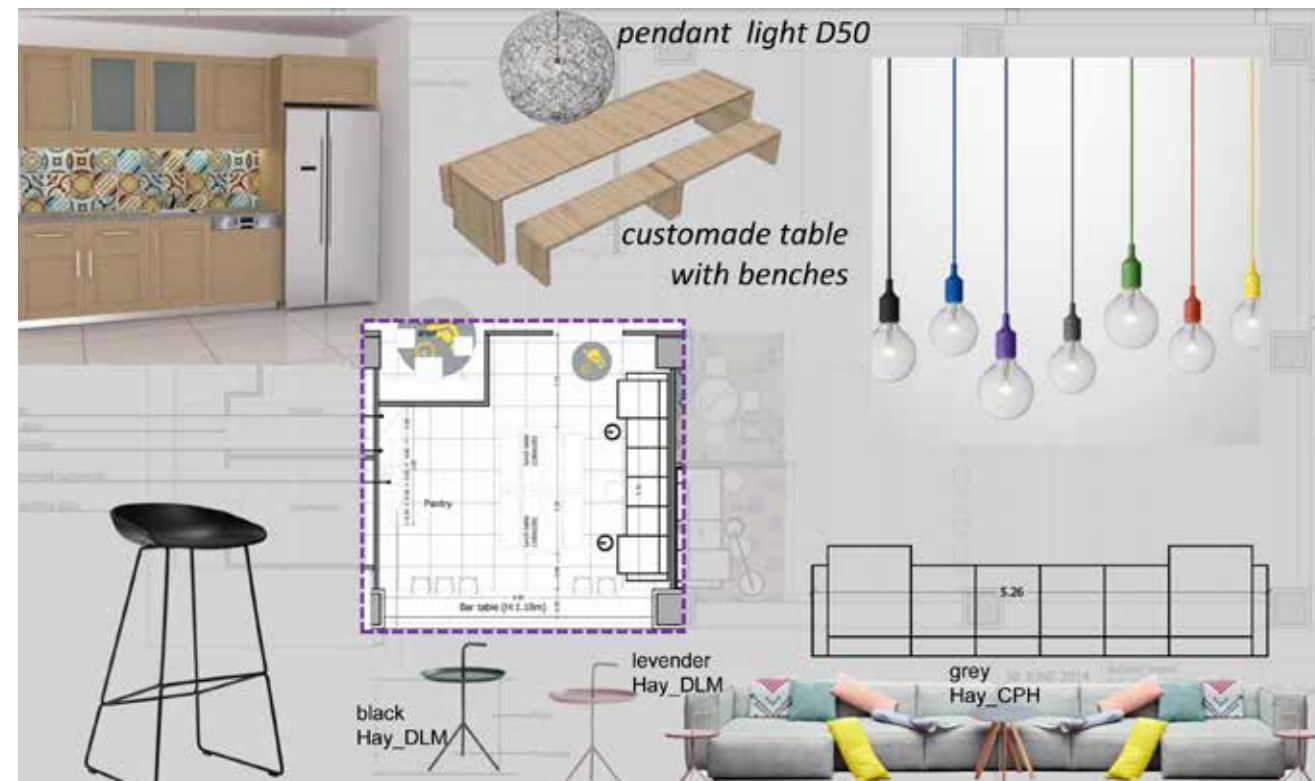
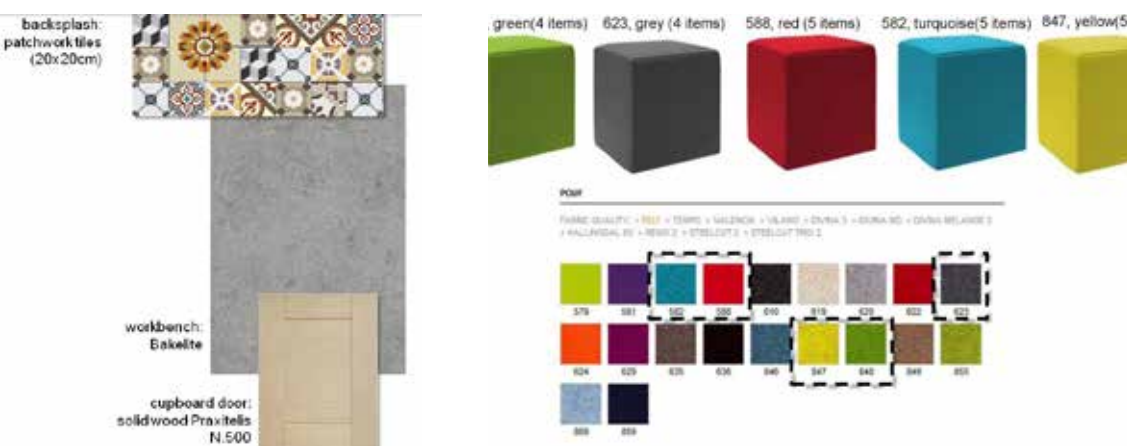

THE PROJECT BRIEF:

The aim was to implement the wish of “Booking.com” company on redesign and refurbishment of its offices in Athens. I was presented with the brief by the company’s design team and I collaborated with the team in order to come up with the design proposal.

CHALLENGES & RESPONSIBILITIES:

- I had to organize the sub-contractor and manage the construction works outside working hours and over weekends, because the offices needed to be open during refurbishment.
- communication with the company’s real estate manager
- co-ordination and management of the sub-contract teams
- completion of the initial 2D & 3D design (CAD)
- architectural drawings (elevations, sections, graphic design concept)
- furniture design
- furniture and material proposals according to company’s policy.



Booking.com Offices refurbishment,
Thessaloniki, Greece

Space Area: 200 sq.m.

Design Date: 12/2014-03/2015

Status: Complete, 2015

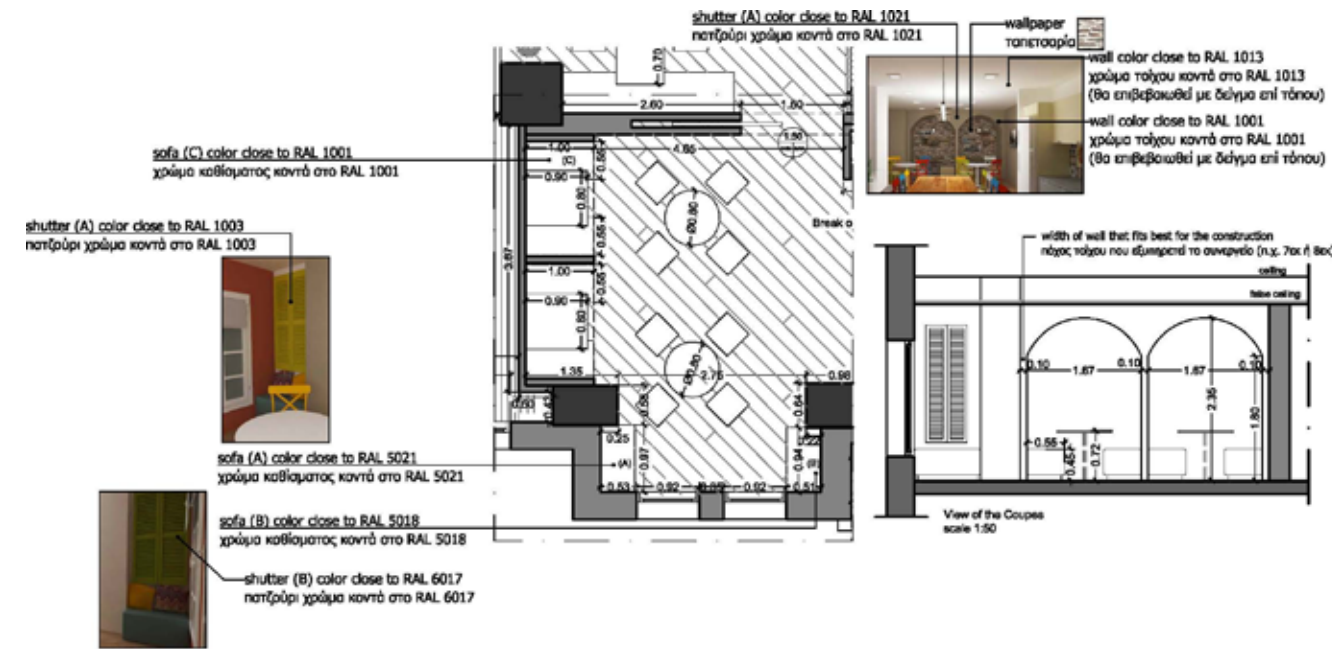

THE PROJECT BRIEF:

I had to decide, along with the company's staff, from a number of selected spaces for the relocation of the "Booking.com" offices in Thessaloniki. I designed the new offices according to the needs and the instructions of "Booking.com". I collaborated with the staff and the company's design team in order to create a professional space that would match the company's standards.

CHALLENGES & RESPONSIBILITIES:

I had to design spaces that would satisfy the company's needs. The selected space was smaller than desired, so the initial design had to be changed in order to accommodate all the necessary activities. Furthermore, the design for the leisure time space had to respond to and incorporate elements of the traditional architectural style of the city of Thessaloniki.

- communication with the company's real estate manager
- co-ordination and management of the sub-contract teams
- completion of the initial 2D & 3D design (CAD)
- architectural drawings (elevations, sections, graphic design concept)
- furniture design
- furniture and material proposals according to company's policy.

Night Club
Glyfada, Attiki, Greece

Space Area: 290 sq.m.
Design Date: 03/2012-05/2012
Status: Complete, 2012



THE PROJECT BRIEF:

The owners of the club wished to create a warm space that everybody could have a panoramic view of the space. The entertainment is achieved with drinking, dancing and flirting with each other. The bar is located in the center of the space where events take place. Dj is also located near the bar and in the middle of the space. There is also a private space for clients who desire isolation from the other people in the club and they want to rest on the sofa. These private spaces are constructed in higher levels so that that they are allowed the eye contact.

Above the bar, a truss is hanged by the ceiling that serves the events, where lights, laser, and dancers can be hanged. The diverse cylinders on the ceiling create a playful effect with the form and the light abolishing the height limits of the space.

The colors of the space are fresh and warm. The curves create a familiar space that everyone can see each other and can follow the events in the bar. The used materials are wood, metal and plasterboard. The grid between the private space and the club divides the two spaces without isolating them.

I was responsible for the design according to the owners' desire and the existing building regulations. A building permit was approved in 2012.

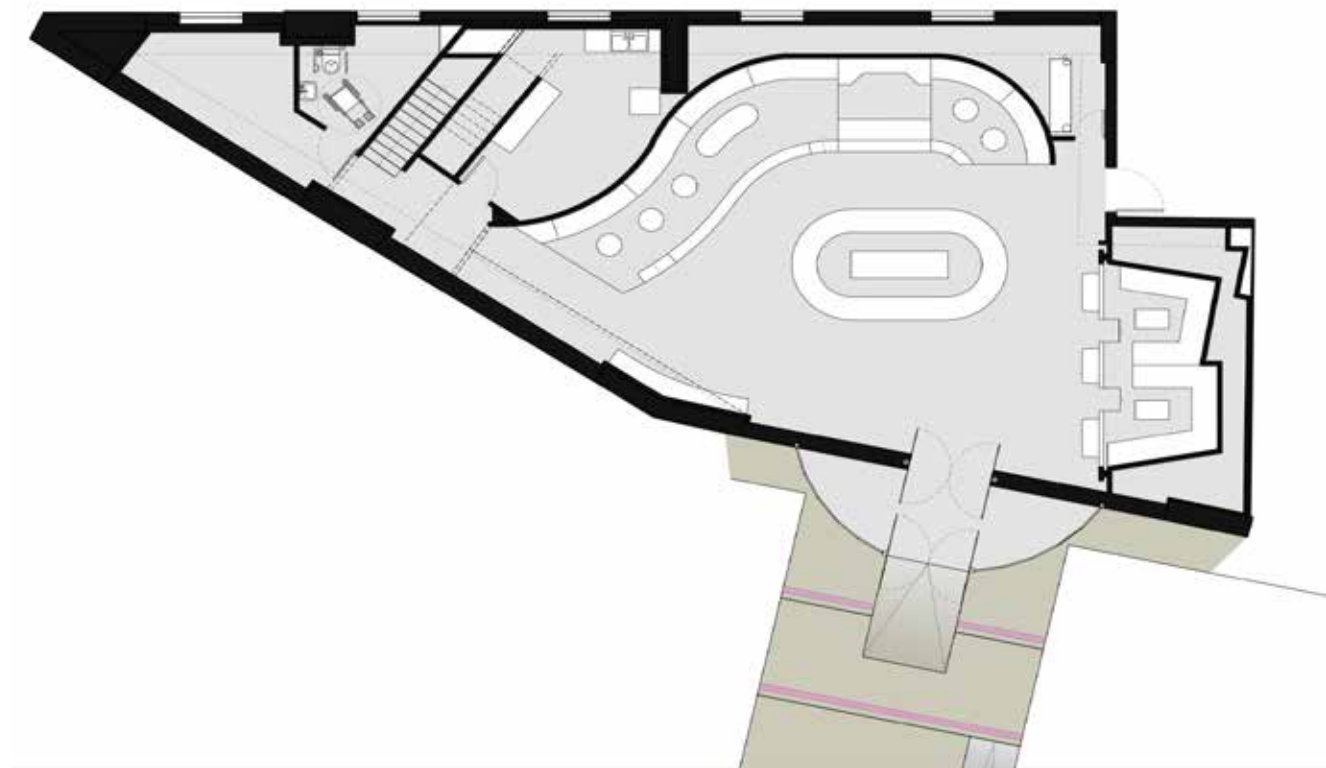



Interiors

Hair-salon design Neo Hrakleio, Attiki, Greece

Space Area: 77 sq.m.
Design Date: 06/2009
Status: Design Proposal

3D visualization



THE PROJECT BRIEF:

The project is the design of a hair-salon in an existing empty space in Neo Hrakleio, Attiki, Greece. Besides hair styling, there will also be included services of manicure and pedicure. The design includes the exterior façade design too. The proposed colors are purple, brown and light green.

3D visualization



3D visualization

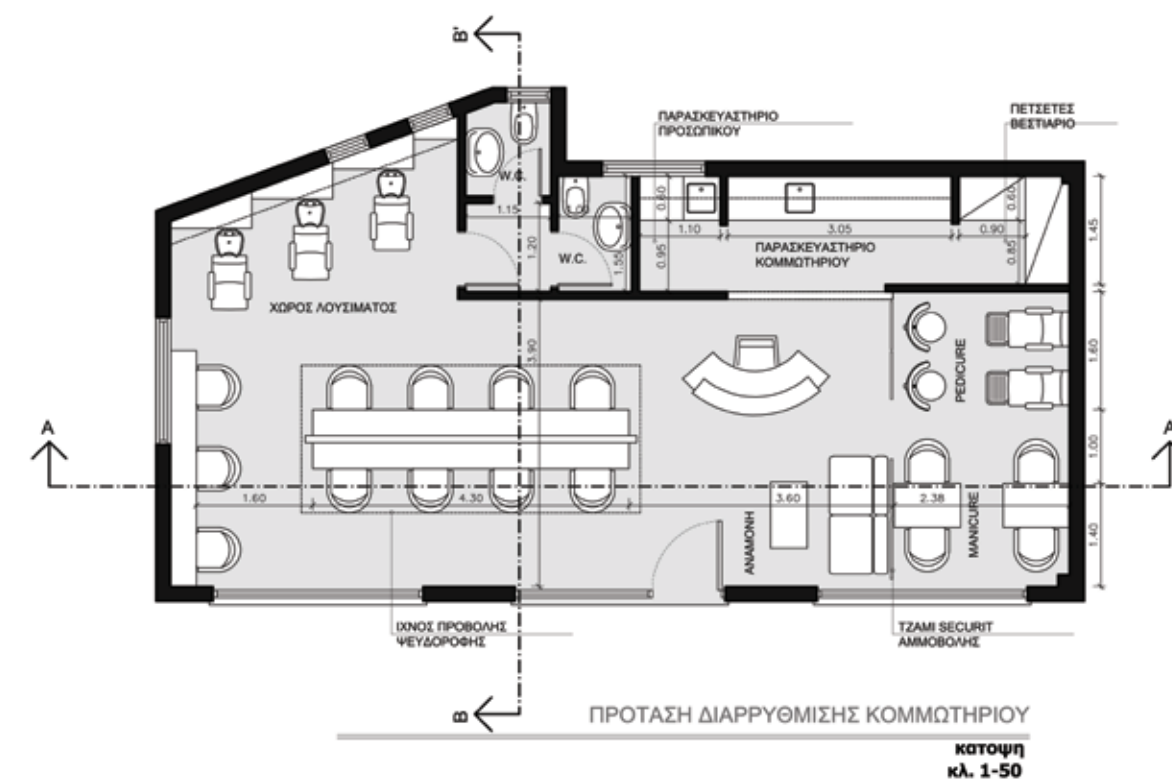

Interiors

Café bar in Plaka, Athens, Greece

Space Area: 200 sq.m.

Design Date: 11/2008-04/2009

Status: Design Proposal



3D visualization

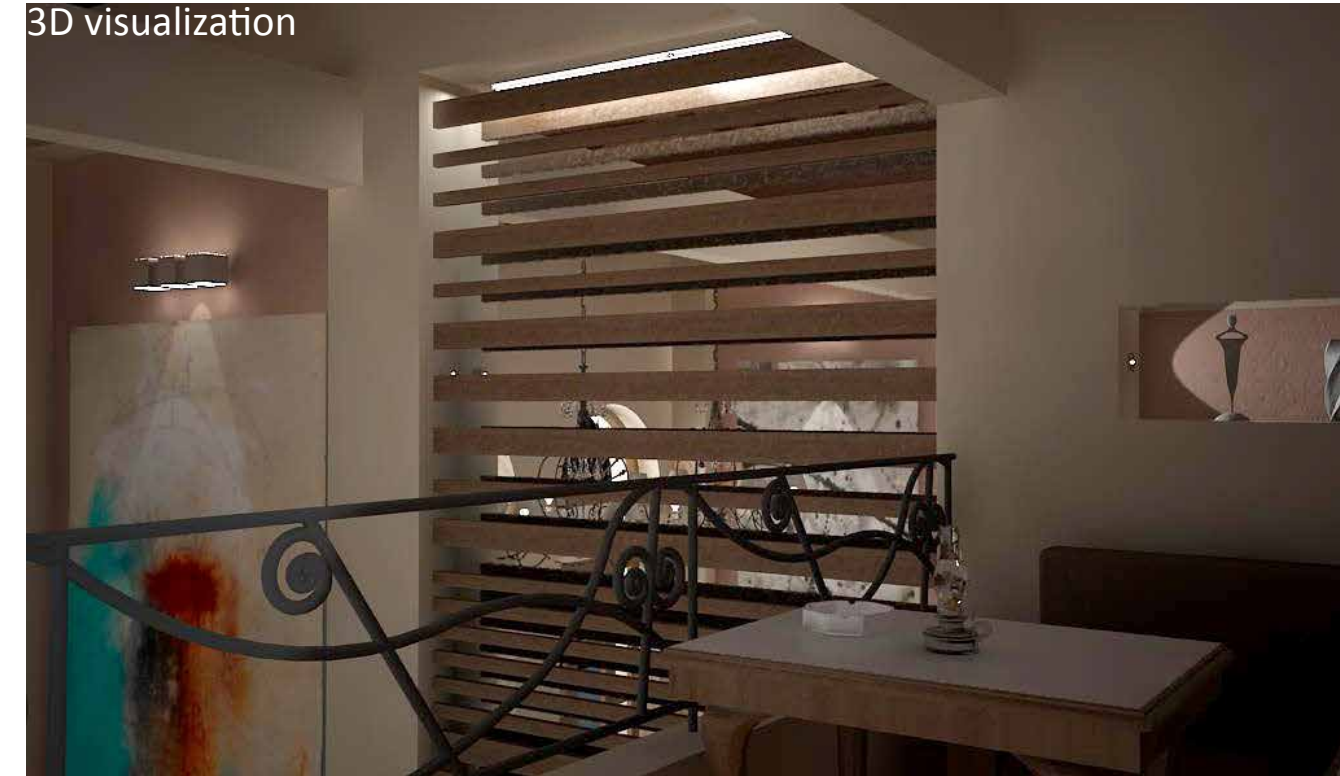

THE PROJECT BRIEF:

The existing café-bar needed re-furbishment and new design. The new design had to fit the style of the oldest historical area of Athens, Plaka. It consists of three levels, the basement where the w.c. and storage is located, the ground floor and the semi-floor. On the ground floor, there is the bar, the kitchen, and the clients' area. Furthermore, semi-floor is converted to a lounge area. Proposed materials are wood and metal. Wall colors are neutral beige and puce.

3D visualization

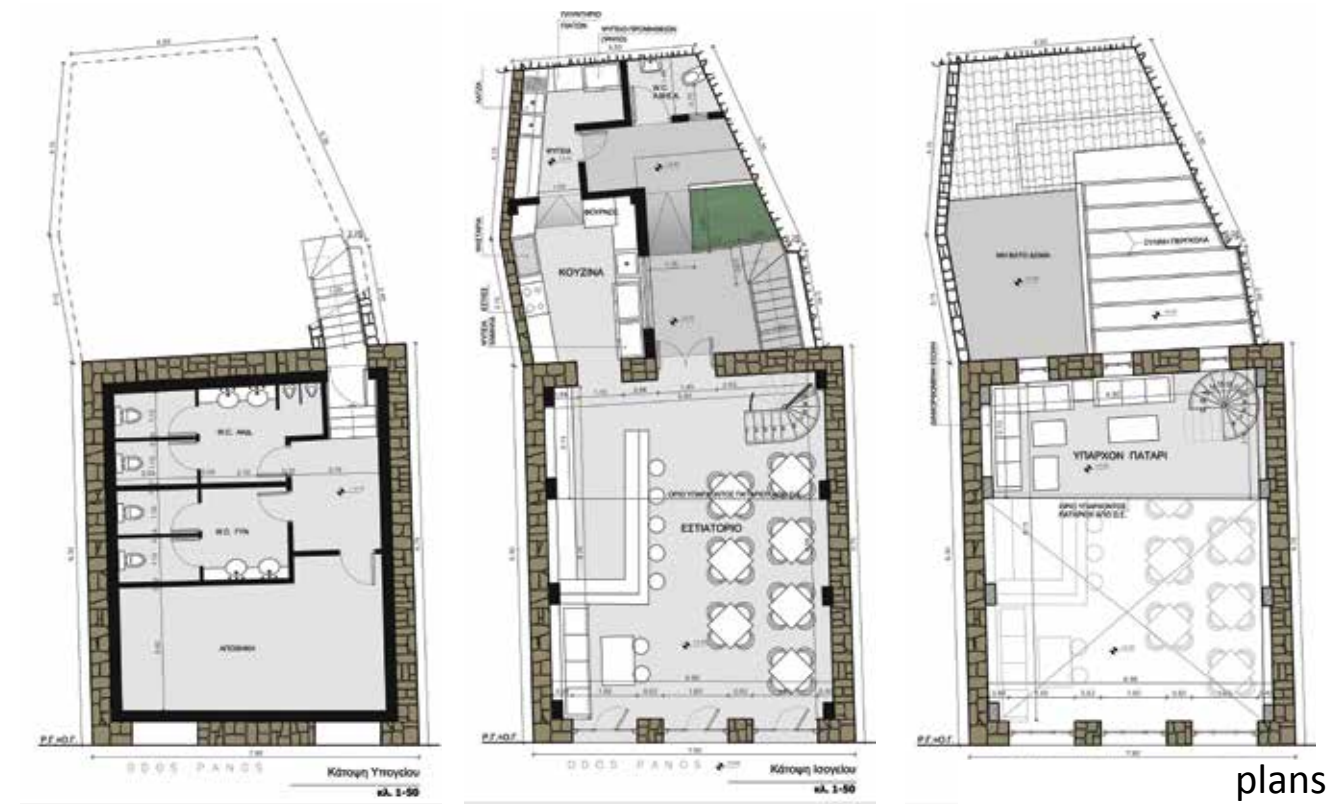

plans

Interior design of a Hotel room
"Room 18", Competition 2016

Space Area: 23,8 sq.m.
Design Date: 07/2016



3D visualization



THE COMPETITION BRIEF:

Room18 is a Pan-European Design competition for the interior design of a typical bedroom in a Greek four-star urban hotel with a total area of 18 – 24m². The competition was announced on 21th of April 2016 and ended on July 2016. The competition attracted 262 submissions, by 580 contributors, from 17 countries.

The Design Concept was to help the guest to get familiar with the room space quickly. Given the fact that the guest stays in a hotel room during a small time period, he/she hasn't enough time to get familiar with space. For this reason, we designed a room that suits the guest's needs and makes him/her feel comfortable during his/her short stay in it. Simple and recognizable materials were chosen such as wood, cement, glass. Glass is also used to separate the bathroom from the bedroom, allowing the guest to see through the whole space. Hidden blinds in the ceiling provide privacy when needed. Warm colors on the walls and the fabrics complete the design concept.



2D section

Bespoke furniture for Offices

Design Date: 03/2014-06/2014

Status: Complete, 2014



plan & 2D elevation

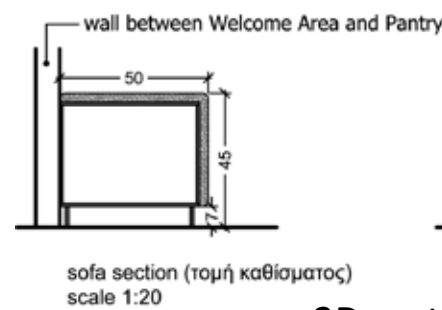
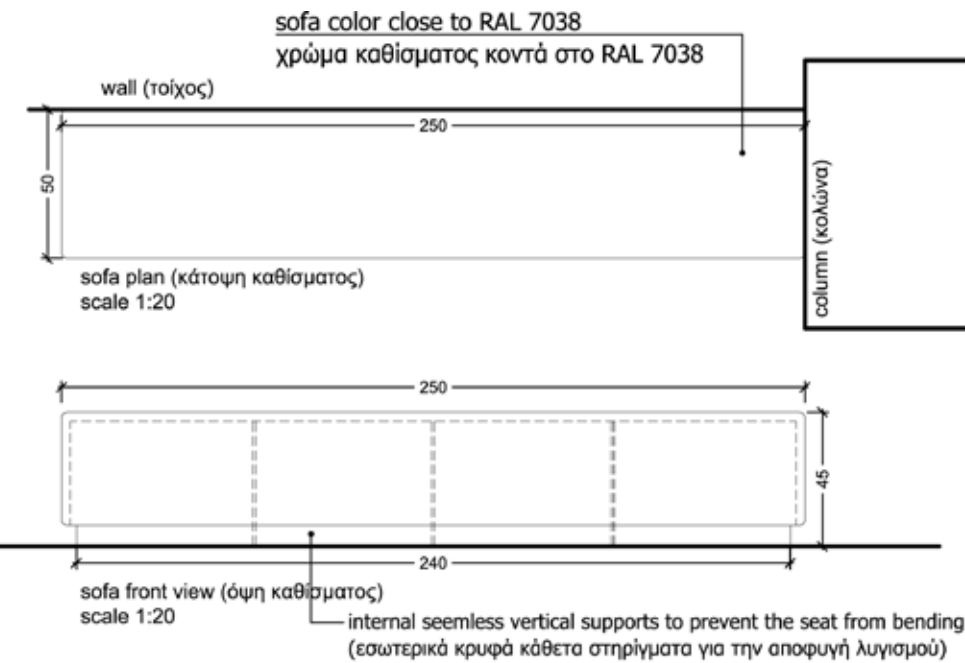

2D section

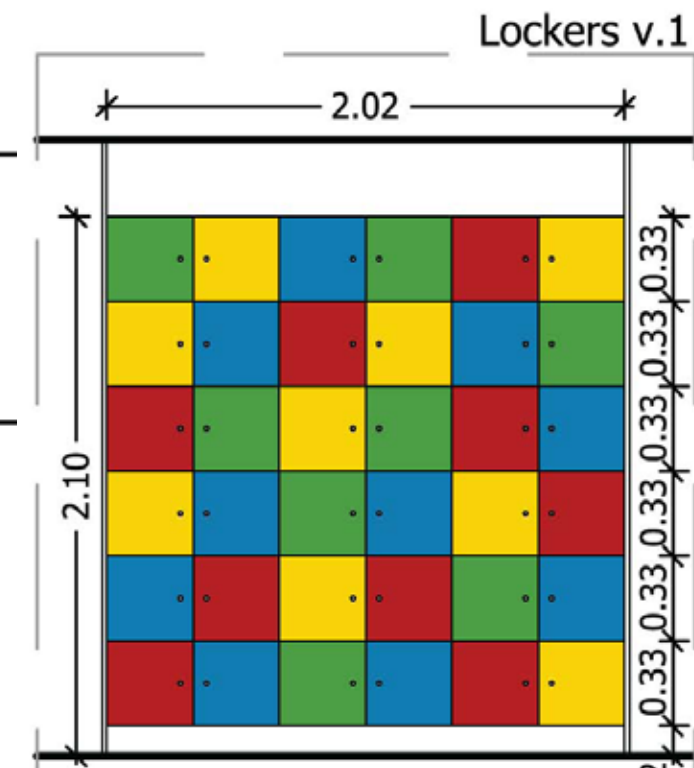

2D section

- RAL 1023
- RAL 3020
- RAL 5015
- RAL 6017

THE PROJECT BRIEF:

The bespoke furniture design was essential for this project in the context of the offices' refurbishment. There were specific needs for the employees that had to be fulfilled during the design procedure.

There was a big column in the middle of the working area that could serve as a printer area. Following this concept, the team proposed furniture, made of wood and painted in the colors of the firm, that serves for the location of printers, the fax and the storage of print supplies.

Furthermore, the furniture with colored lockers serves for storage of the personal belongings of the employees. The kitchen suits very well with the other elements of the space.



3D visualization 2D elevation

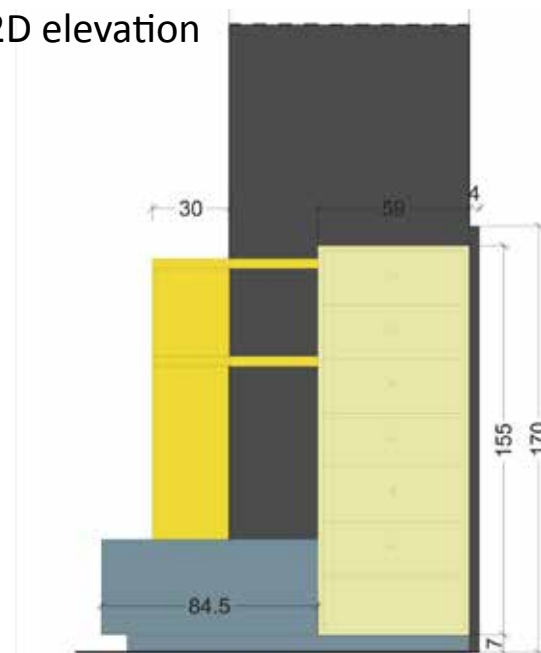

Bespoke sofa

Design Date: 04/2013-07/2013

Status: Study

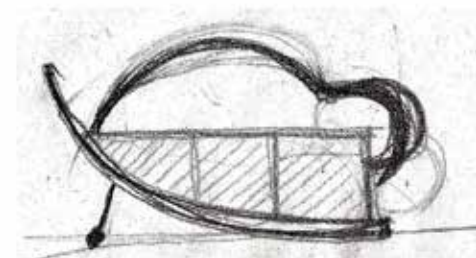
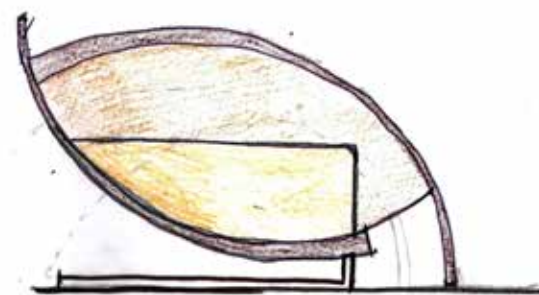
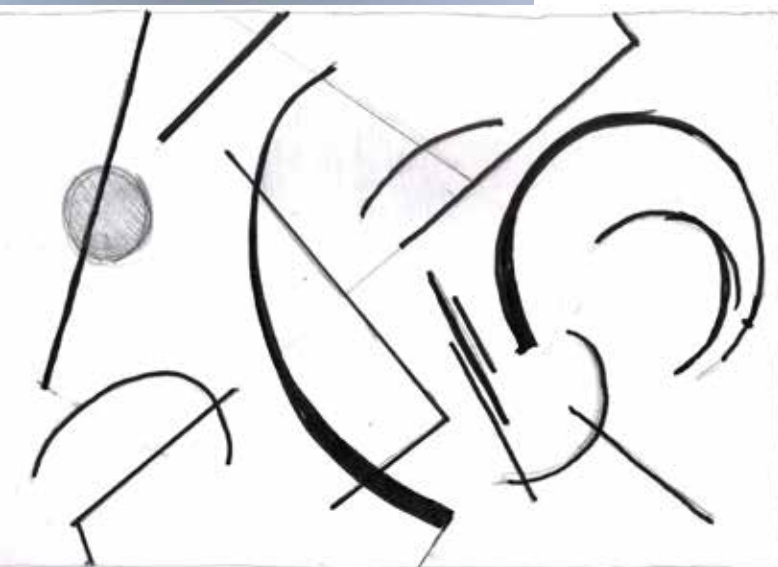

3D drawings

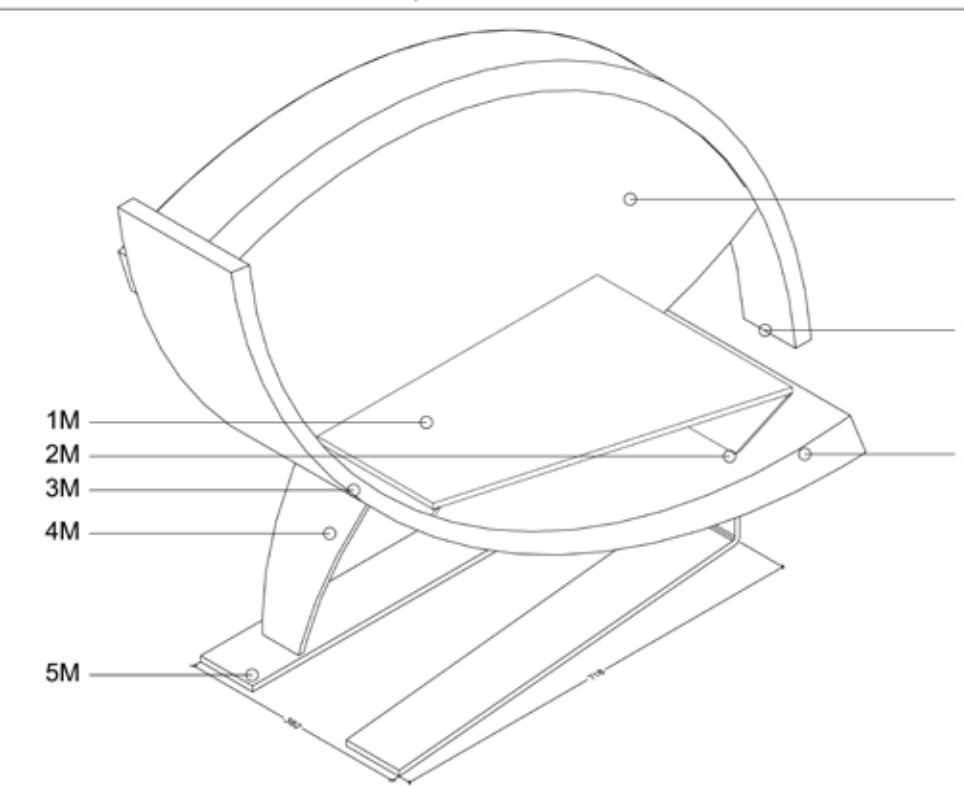
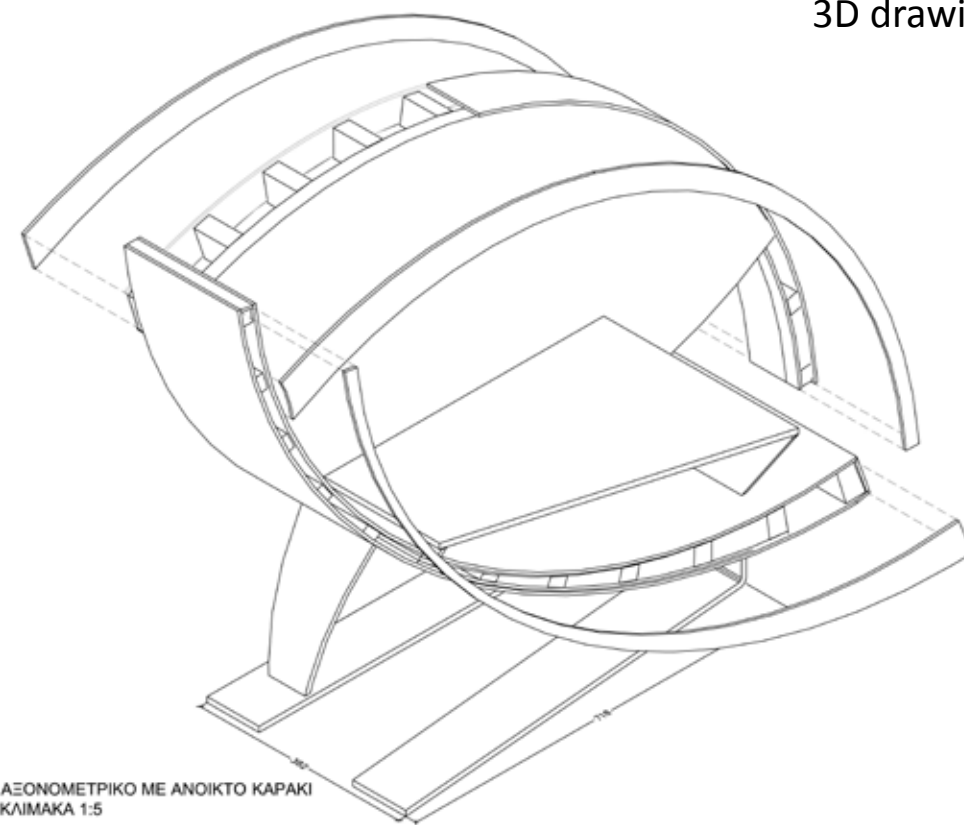

Πίνακας Υλικών

α/α	σκίτσο	ονοματ/γία	διαστάσεις	τεμ.	υλικό	τελείωμα
ΠΛΑΤΗ						
1Π		πλάτη	785x315x18	1	κόντρα πλακέ	λάκα σασινέ
ΤΟΞΑ						
1Τ		πλάτη	1670x(30-81) x100	1	κόντρα πλακέ	λάκα σασινέ
2Τ		καθισμα	1429x(30-76) x(218-401)	1	κόντρα πλακέ	λάκα σασινέ
ΜΕΤΑΛΙΚΗ ΣΤΗΡΙΞΗ						
1Μ		κάθισμα	538x(223-375) x10	1	λαμαρίνα	RAL 7035
2Μ		δεξ. πλαινό καθίτος	(375-275)x146 x10	1	λαμαρίνα	
3Μ		αρ. πλαινό καθίτος	(226-216)x35 x10	1	λαμαρίνα	
4Μ		αρ. πλαινό στήριξης		1	λαμαρίνα	
5Μ		κάτω στήριξη		1	λαμαρίνα	

THE PROJECT BRIEF:

This is a study of the design of a love sofa. The project is inspired by Kadinsky, Transverse Line, (1923), Dusseldorf, Germany. Along with the sofa, a side table has been designed. The base of the sofa is metal and the other proposed material is lacquered wood combined with fabric. The combinations of multiple colors and fabric are presented in 3D rendered images. It can be used alone or combined with other furniture.

Bespoke storage console

Design Date: 04/2016

Status: complete, 2016



THE PROJECT BRIEF:

The client wished a custom-made storage console for the entrance of her house. She demanded furniture that would contain cava, closet, drawers, and cupboards for storage. The concept was to design furniture that would be a wardrobe and a console in the entrance of the house. On the right side of the closet, the mirror makes space seem bigger and serves as a beauty accessory.

The proposed material is vanilla lacquered wood combined with brown wenge color. The upper cupboard doors are proposed semitransparent glass with an aluminium frame.



3D visualisation

3D drawings

